

# DECÓ

*and more*

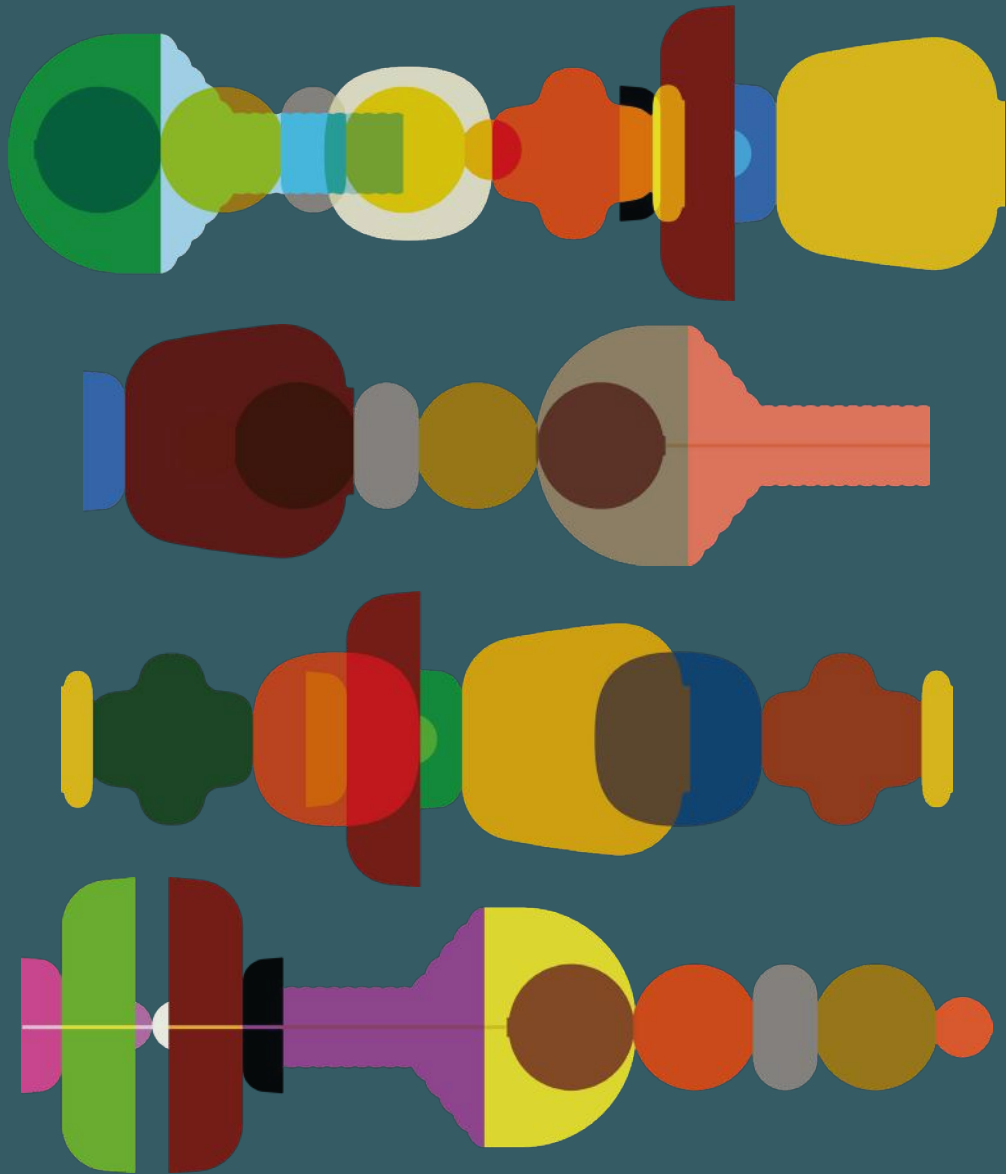

F E R R O L U C E

# DECÒ and more

Dalla contaminazione di visioni e stili differenti nascono quattro nuove lampade che impreziosiscono la collezione DECò: Eclair, Voilà, Yakitori e Habea. Frutto delle menti non convenzionali di Giorgio Biscaro, Art Director del Brand, e di due nuovi designer, Tommaso Caldera e Muka Design Lab, questi veri e propri oggetti di design celebrano un linguaggio stilistico distintivo per originalità e capace di distinguersi nel mercato dell'illuminazione. Una gioia per gli occhi. Enjoy!

*From the contamination of different visions and styles come four new lamps that embellish the DECò collection: Eclair, Voilà, Yakitori and Habea. The product of the unconventional minds of Giorgio Biscaro, Art Director of the Brand, and two new designers, Tommaso Caldera and Muka Design Lab, these true design objects celebrate a stylistic language that is distinctive in originality and capable of standing out in the lighting market. A joy for the eyes. Enjoy!*

8 - 13



## ECLAIR

C2770

14 - 19

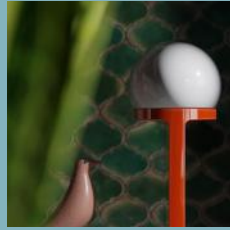

## HABEA

C2780

20 - 25



## VOILÀ

C2775

26 - 31

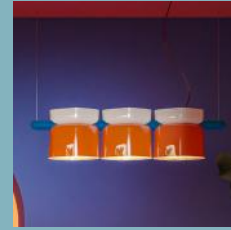

## YAKITORI

C2790



Le forme arrotondate di un grande biscotto farcito e la frizzante palette cromatica in stile cotton-candy fanno fare di Eclair un prodotto ironico e altamente riconoscibile. Pensata per un montaggio a parete, è composta da due elementi a incastro che sembrano comprimersi strettamente uno contro l'altro, quasi fossero delle grandi caramelle gomose. Frontalmente, un elemento in vetro permette una generosa distribuzione della luce nell'ambiente circostante e gioca con le superfici smaltate della ceramica e dalla loro calda artigianalità.

*The rounded shapes of a large, filled cookie and the vibrant cotton-candy-inspired color palette make Eclair an ironic and highly recognizable product. Designed for wall mounting, it consists of two interlocking elements that appear to press closely against one another, resembling large gummy-like candies. The front-facing glass element ensures a generous distribution of light into the surrounding space and interacts with the glazed ceramic surfaces, highlighting their warm craftsmanship.*

# ECLAIR

C2770

# ECLAIR

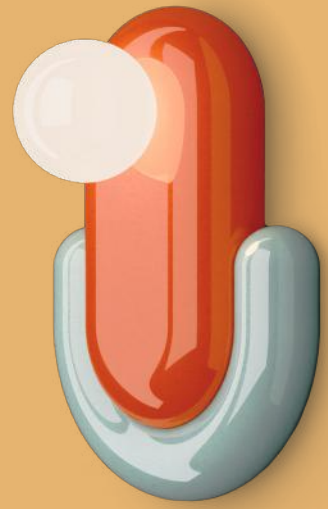

G2770

Finiture disponibili / Available finishes:

Ceramica / Ceramic



GGI



MVB



AAZ



Guardala online  
See it online

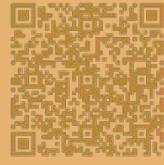

**art. C2770**  
Ceramica / Ceramic

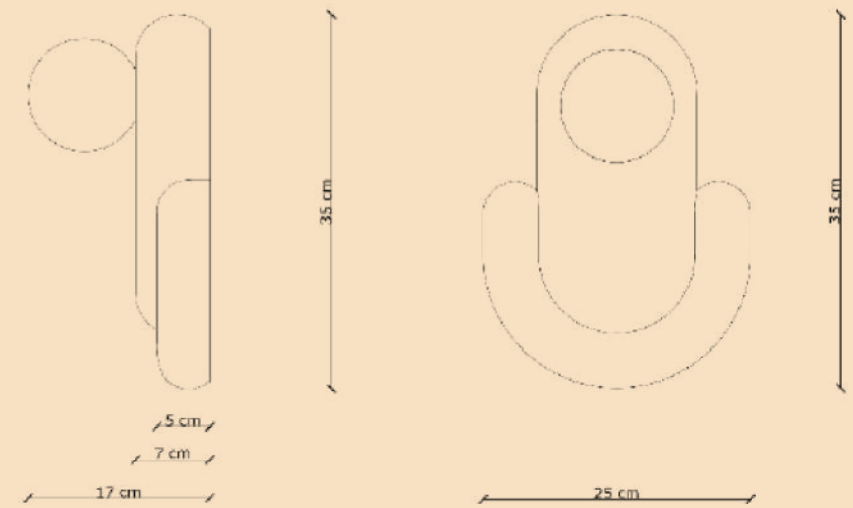

**art. C2770**  
peso netto / net weight Kg 2,54  
1 x MAX 25W G9





Ironica rivistazione del classico Bauhaus di Wagenfeld, ma anche una complice strizzata d'occhio a celebri portafrutta enzomariani, Habea fa della putrella un elemento centrale. Lampada da tavolo in ceramica e vetro soffiato dotata di ottimo comfort visivo, Habea ci appare sempre mutevole a seconda dell'angolo di osservazione: ora esile e quasi diafana, ora solida ed evidente, adatta a decorare un ingresso domestico, ma anche illuminare la scrivania di lavoro, o un accogliente soggiorno.

*An ironic reinterpretation of Wagenfeld's classic Bauhaus, but also a hint to Enzo Mari's famous fruit bowls, Habea makes the beam its central element. This table lamp, made of ceramic and blown glass, provides excellent visual comfort. Habea always appears changeable depending on the viewing angle: sometimes slender and almost diaphanous, other times solid and prominent. Suitable for decorating a home entrance, illuminating a work desk, or creating the ambiance to a living room.*

# HABEA

C2780



# HABEEA

C2780

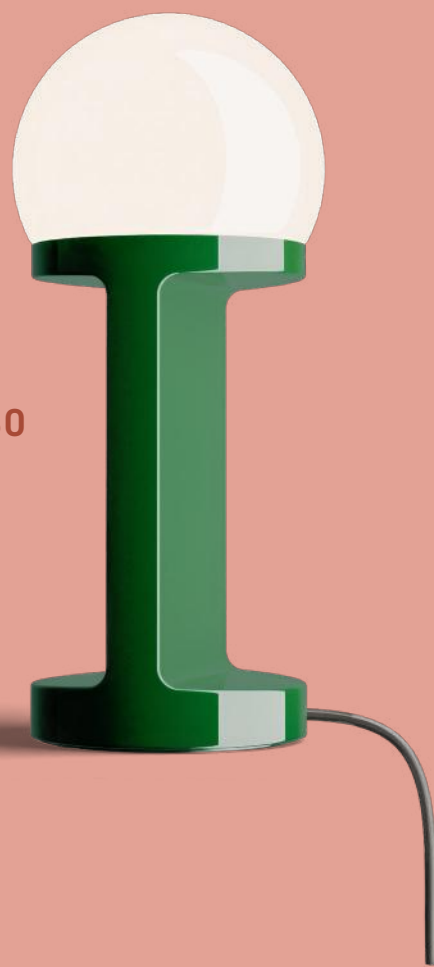

Finiture disponibili / Available finishes:

Ceramica / Ceramic



GIA

AVO

CRM

BLR

VBA



# HABEA

Guardala online  
See it online



**art. C2780**  
Ceramica / Ceramic

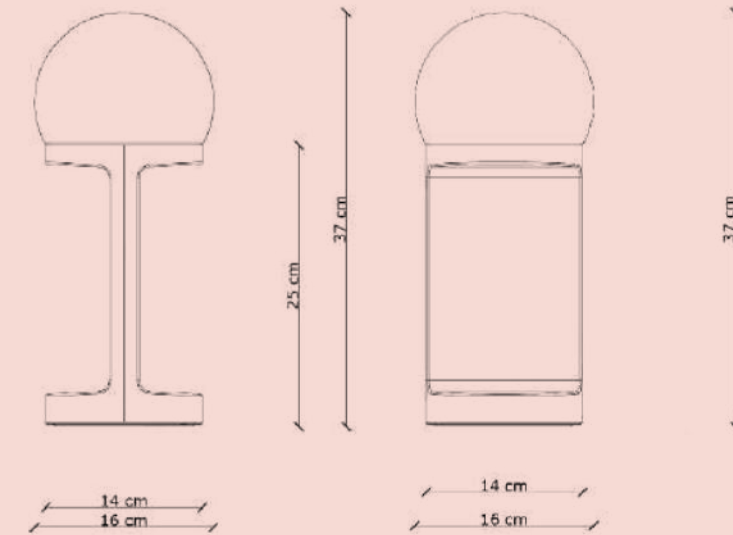

**art. C2780**  
peso netto / net weight Kg 2,47  
1 x MAX 53W E27





**Voilà** rappresenta l'onomatopea del gesto finale del ceramista che estrae il pezzo dallo stampo. Realizzata tramite una pressatura avanzata della ceramica, permette di ottenere spigolosità impossibili con le tecniche tradizionali, assemblando i due elementi concentrici (smaltati con colori a contrasto) alla perfezione. Ideale per montaggio a parete o a soffitto, illumina sia spazi medi che corridoi lunghi se usata in sequenza.

*Voilà captures the onomatopoeia of the ceramist's final gesture when removing the piece from the mold. Created through advanced ceramic pressing, it allows for sharp edges unattainable with traditional methods, assembling its two concentric elements (glazed in contrasting colors) to perfection. Perfect for wall or ceiling mounting, it illuminates both medium spaces and long corridors when used in sequence.*

# VOILÀ

C2775

# VOILÀ

C2775



Finiture disponibili / Available finishes:

Ceramica / Ceramic



GSC



ACR



ABR



PGA



Guardala online  
See it online



**art. C2775**  
Ceramica / Ceramic

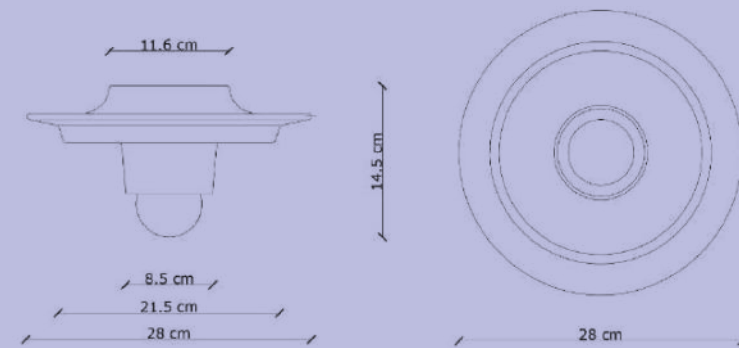

**art. C2775**  
peso netto / net weight Kg 3,05  
1 x MAX 53W E27





Con i suoi elementi multipli sospesi a mezz'aria che paiono quasi essere infilati su un grande stecco, Souvlaki/Yakitori ci resituisce l'immagine allegra ed epicurea che si respira attorno a una bancarella di street food, coi suoi colori folkloristici e il brulicare di clienti e insegne. Gli elementi ceramici, infatti, pensati in diverse associazioni cromatiche, vengono montati a sandwich su una barra metallica colorata a contrasto, garantendo la flessibilità costruttiva necessaria per illuminare la superficie di un bancone, le scrivanie di un ufficio, una tavola imbandita o anche i corridoi di uno spazio retail.

*With its multiple elements suspended in mid-air that almost seem to be skewered on a large stick, Yakitori brings to mind the cheerful and epicurean atmosphere surrounding street food stalls, with its folkloric colors and the bustling customers and signs. The ceramic elements, designed in various color combinations, are clipped to a contrasting-colored metal bar, providing the necessary structural flexibility to illuminate the surface of a counter, office desk, dining table or even the corridors of any retail space.*

# YAKITORI

C2790

# YAKITORI



C2790

Finiture disponibili / Available finishes:

Ceramica / Ceramic



GCR



5AV



GBR



AVB



AMO



CAG

Guardala online  
See it online

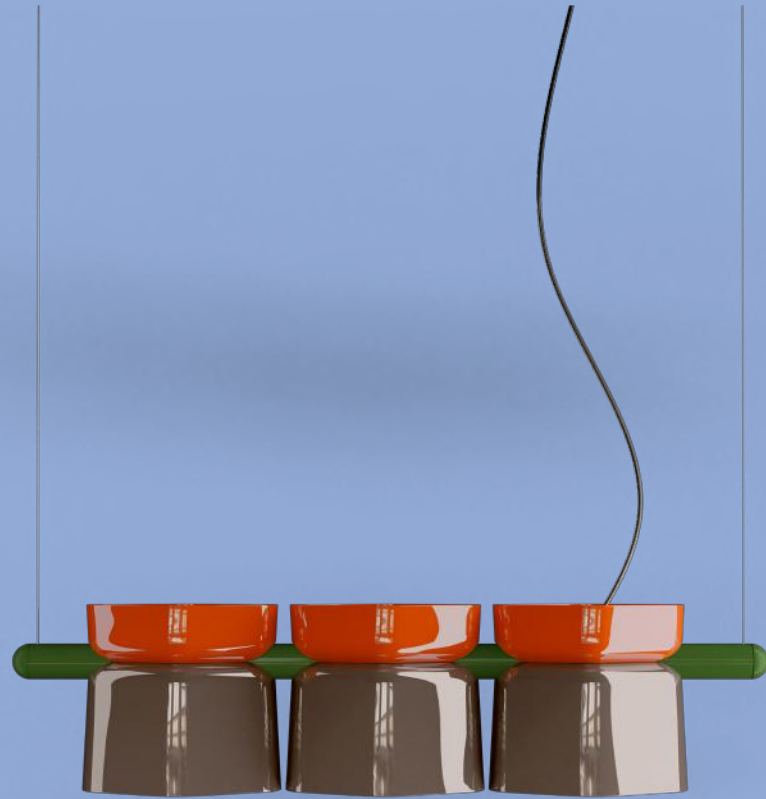

**art. C2790**  
Ceramica / Ceramic

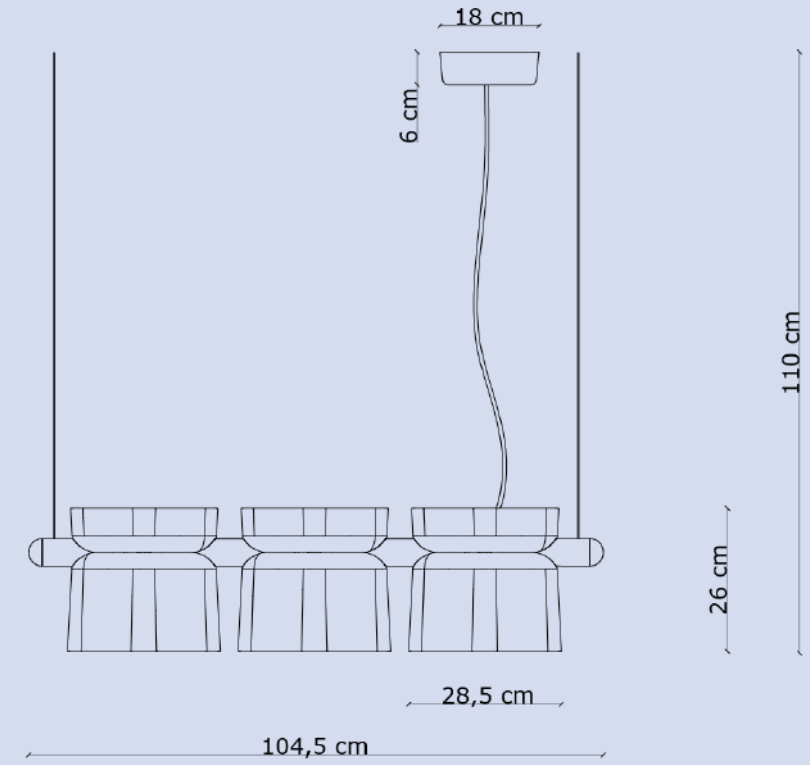

**art. C2790**  
peso netto / net weight Kg 11,90  
3 x MAX 53W E27





# DESIGNERS

DESIGNERS

**GIORGIO BISCARO**

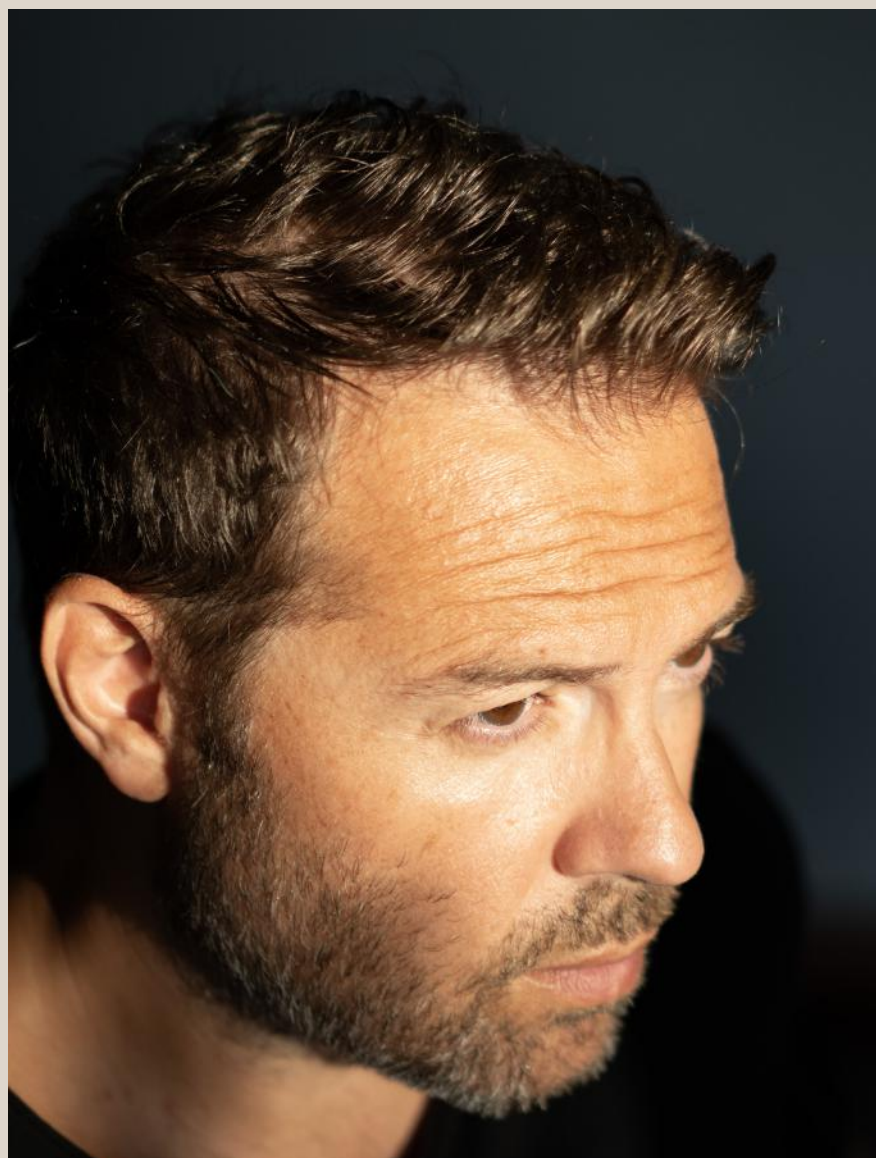

Designer e Art Director di Ferroluce, è dalla sua mano che sono nate le lampade più iconiche della collezione DECò. Una collaborazione nata dal desiderio condiviso di creare dei prodotti capaci di valorizzare la profonda conoscenza della materia ceramica che contraddistingue il brand, ma anche la ricerca di nuove tecnologie e materiali che lo guidino verso il futuro dell'illuminazione.

*Designer and Art Director of Ferroluce, it is from his hand that the most iconic lamps of the DECò collection were born. A collaboration born from the shared desire to create products capable of enhancing the deep knowledge of ceramic material that distinguishes the brand, but also the search for new technologies and materials that guide it towards the future of lighting.*

**TOMMASO CALDERA**



Duo di designer baschi, molto noti online, che all'attivo vantano diverse collaborazioni di spicco. Laxmi e Lucas hanno una visione del design che va oltre l'estetica, e grande abilità nel trasformare una semplice idea in una lampada capace di raccontare una storia. Con Ferroluce hanno realizzato Habea, un omaggio al classico Bauhaus di Wagenfeld che mescola con intelligenza ceramica e vetro soffiato.

*Duo of Basque designers, well known online, who have several prominent collaborations to their credit. Laxmi and Lucas have a vision of design that goes beyond aesthetics, and great skill in transforming a simple idea into a lamp capable of telling a story. With Ferroluce they created Habea, a tribute to Wagenfeld's classic Bauhaus that cleverly mixes ceramic and blown glass.*

**MUKA DESIGN LAB**



Figura di rilievo del design italiano, Tommaso Caldera unisce esperienza internazionale e passione per l'innovazione. Direttore artistico della storica B-Line, redattore per Elle Decor Italia e docente NABA e Politecnico, dalla sua esperienza pluriennale è nata Voilà, una lampada che omaggia la ceramica con ingegno e sapienza, ottenuta grazie a lavorazioni avanzate che la rendono un vero must-have dall'eleganza senza tempo, perfetta per tutti gli amanti del design.

*A leading figure in Italian design, Tommaso Caldera combines international experience with a passion for innovation. Artistic director of the historic B-Line, editor for Elle Decor Italia and lecturer at NABA and Politecnico, from his many years of experience came Voilà, a lamp that pays homage to ceramics with ingenuity and wisdom, achieved through advanced processing that makes it a true must-have with timeless elegance, perfect for all design lovers.*

TUTTI I NOSTRI ARTICOLI SONO PRODOTTI ESCLUSIVAMENTE IN ITALIA  
E RISPETTANO RIGOROSAMENTE LE NORMATIVE **CE**.

*ALL OUR PRODUCTS ARE MADE IN ITALY AND BUILT  
IN THE RESPECT OF **CE** LAWS.*

L'AZIENDA SI RISERVA IL DIRITTO DI MODIFICARE SENZA PREAVVISO  
TUTTE LE FINITURE E GLI ARTICOLI PRESENTI IN QUESTO CATALOGO.  
I COLORI REALI DELLE FINITURE POSSONO DIFFERIRE DA QUELLE STAMPATE.

*THE COMPANY RESERVES THE RIGHT TO MODIFY WITHOUT WARNING  
ALL THE FINISHES AND PRODUCTS INCLUDED WITHIN THIS CATALOGUE.  
THE ACTUAL COLORS OF THE FINISHES MAY BE DIFFERENT THAN PRINTED ONES.*

associato



consorzio per la raccolta e lo smaltimento  
delle apparecchiature di illuminazione

COPYRIGHT FERROLUCE SRL®

Printed by: Poligrafiche San Marco - ITALY

Graphic: **RGB**

# FERROLUCE

*Scansionando i QR code all'interno del catalogo è possibile collegarsi al sito  
www.ferroluce.it dove potrai trovare immagini, finiture, schede tecniche,  
istruzioni di montaggio, disegni 2d, file 3ds e scaricare facilmente anche gli altri  
due cataloghi Ferroluce.*

*It is possible to access the website www.ferroluce.it by scanning the QR code  
in the catalogue. You can find images, finishes, technical data, installation  
instructions, 2D models, 3D files and download all Ferroluce catalogues.*



## STABILIMENTO PRODUCTION DEPARTMENT

Z.I. I VIA ARMENTARESSA nr.10  
34076 ROMANS D'ISONZO (GO) | ITALIA  
T. +39 0481 909541

## SEDE ED ESPOSIZIONE HEAD OFFICE AND SHOWROOM

VIA XXV MAGGIO nr.17  
34076 ROMANS D'ISONZO (GO) | ITALIA

## SEDE AMMINISTRATIVA MANAGEMENT

VIA TIRO nr.19  
30126 VENEZIA LIDO (VE) | ITALIA

INFO@FERROLUCE.IT | WWW.FERROLUCE.IT



F E R R O L U C E

# DECÒ

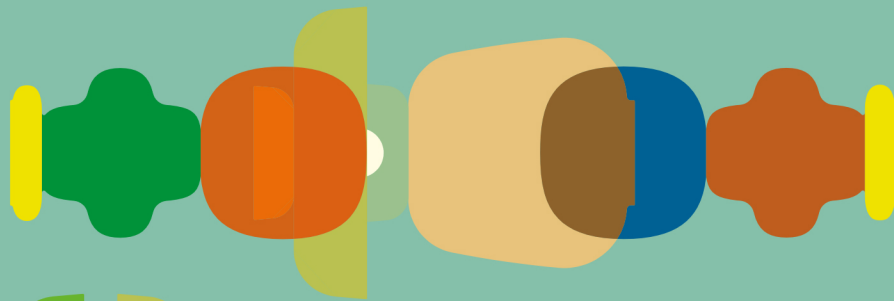
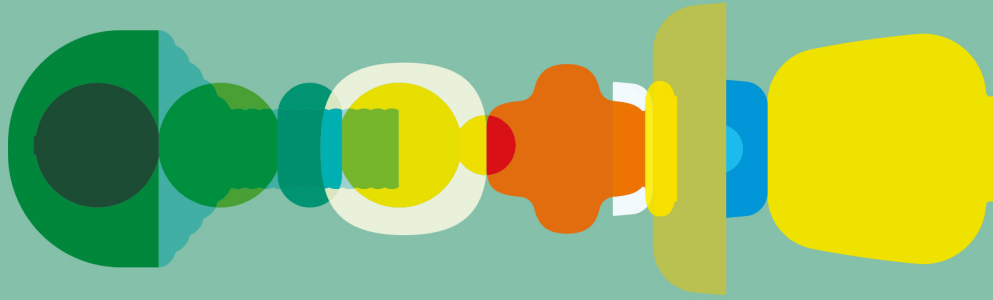



# CATALOGO 2023

Nata dalla passione per la produzione di elementi per l'illuminazione in ceramica, con un'estrema cura per i dettagli e la loro unicità, DECò rappresenta il desiderio di esplorare una nuova espressività, unica e libera da schemi.

*The passion for the production of ceramic lighting fixtures with an extreme attention to details, led us to the creation of Decò collection. Decò represents the desire to explore a new expression, unique and out of schemes.*

10 - 21



## AFOXÉ

C2640 - C2641 - C2642 - C2646 - C2656 -  
C2657 - C2658 - C2659

22 - 29



## AYRTON

C2550 - C2553

38 - 45



## BELLOTA

C2540 - C2541 - C2542

70 - 77

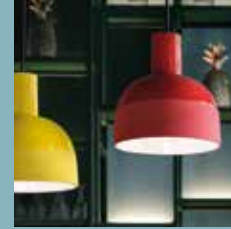

## CAXIXI

C2400

78 - 85

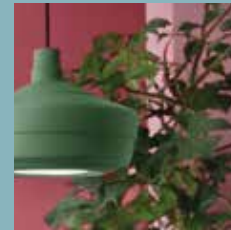

## CHURUATA

C2580

86 - 93



## COPACABANA

*C2680 - C2681 - C2682 - C2683 - C2684 -  
C2685*

94 - 101



## CORCOVADO

*C2740 - C2742 - C2744*

102 - 117



## LARIAT

*C2510 - C2511 - C2512 - C2530 - C2531 -  
C2532 - C2710 - C2711 - C2712*

118 - 125



## MADAME GRÈS

*C2570 - C2571 - C2572 - C2573*

126 - 133



## MARACANÀ

*C2741 - C2743 - C2745*

142 - 153



## PI

*C985 - C986 - C1792 - C1793 - C2500 -  
C2501 - C2502*

154 - 161



## SELARÓN

*C2730*

162-169



## FERROLUCE

*Storia - Brand - Valori - Materiali  
History - Brand - Values - Materials*





*In foto / in the picture:*  
C2641 VSA



# AFOXÉ

C2640	C2642	C2656	C2658
C2641	C2646	C2657	C2659

# AFOXÉ

C2659



Come nelle percussioni tradizionali afro-brasiliane, la rigidità delle superfici viene interrotta da immaginari tagli netti, una gabbia che sembra stringersi attorno a un volume che, al contrario, preme per uscirvi e trasmettere la propria vitalità, a sua volta testimoniata dal dinamismo delle finiture lucide e brillanti volte a proteggere il cuore luminoso racchiuso al loro interno.

*As seen in traditional Afro-Brazilian percussion instruments, the stiffness of the surfaces is interrupted by imaginary clean cuts, a cage that seems to close around a volume that, on the contrary, pushes to emerge and express its vitality, which in turn is revealed by the dynamism of the glossy, shiny finishes that protect the luminous heart enclosed within them.*



*In foto / in the picture:*  
C2657 MIX

# AFOXÉ

Guardala online  
See it online



C2641



art. C2640  
Ceramica / ceramic



art. C2641  
Ceramica / ceramic



art. C2642  
Vetro / glass



Finiture disponibili / Available finishes:

Ceramica / ceramic



CRM GRS APO TUR VSA MOK

Vetro / glass



CRI BRO

# AFOXÉ

Guardala online  
See it online



C2657

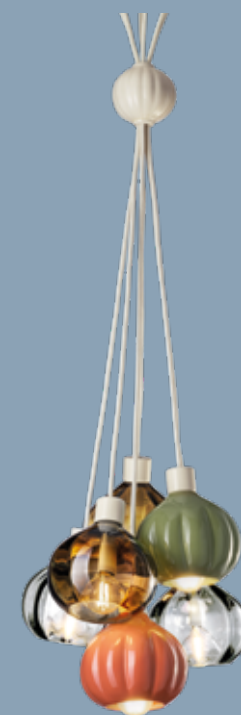

**art. C2646**

*Ceramica / vetro  
Ceramic / glass*

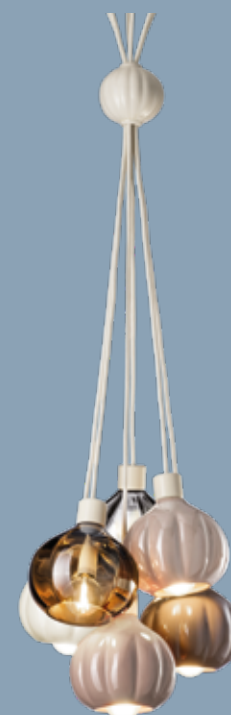

**art. C2656**

*Ceramica / vetro  
Ceramic / glass*

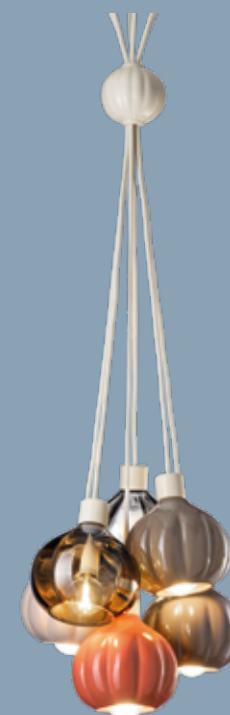

**art. C2657**

*Ceramica / vetro  
Ceramic / glass*

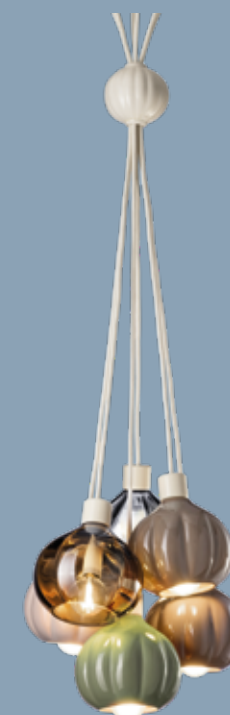

**art. C2658**

*Ceramica / vetro  
Ceramic / glass*

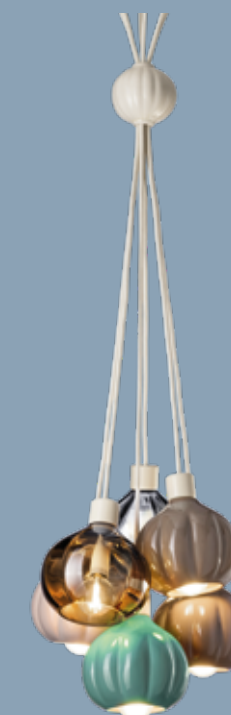

**art. C2659**

*Ceramica / vetro  
Ceramic / glass*



Finiture disponibili / Available finishes:

Ceramica / ceramic



Vetro / glass



CRM

GRS

AP0

TUR

VSA

MOK

CRI

BRO

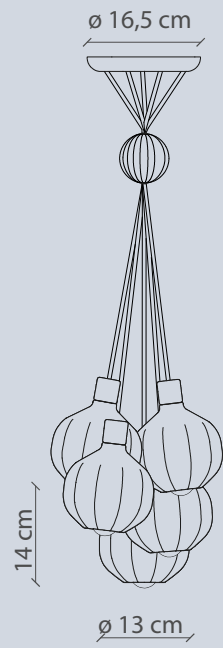

**art. C2646 - C2659**  
*peso netto / net weight Kg 4,14*  
*6 x MAX 28W E14*

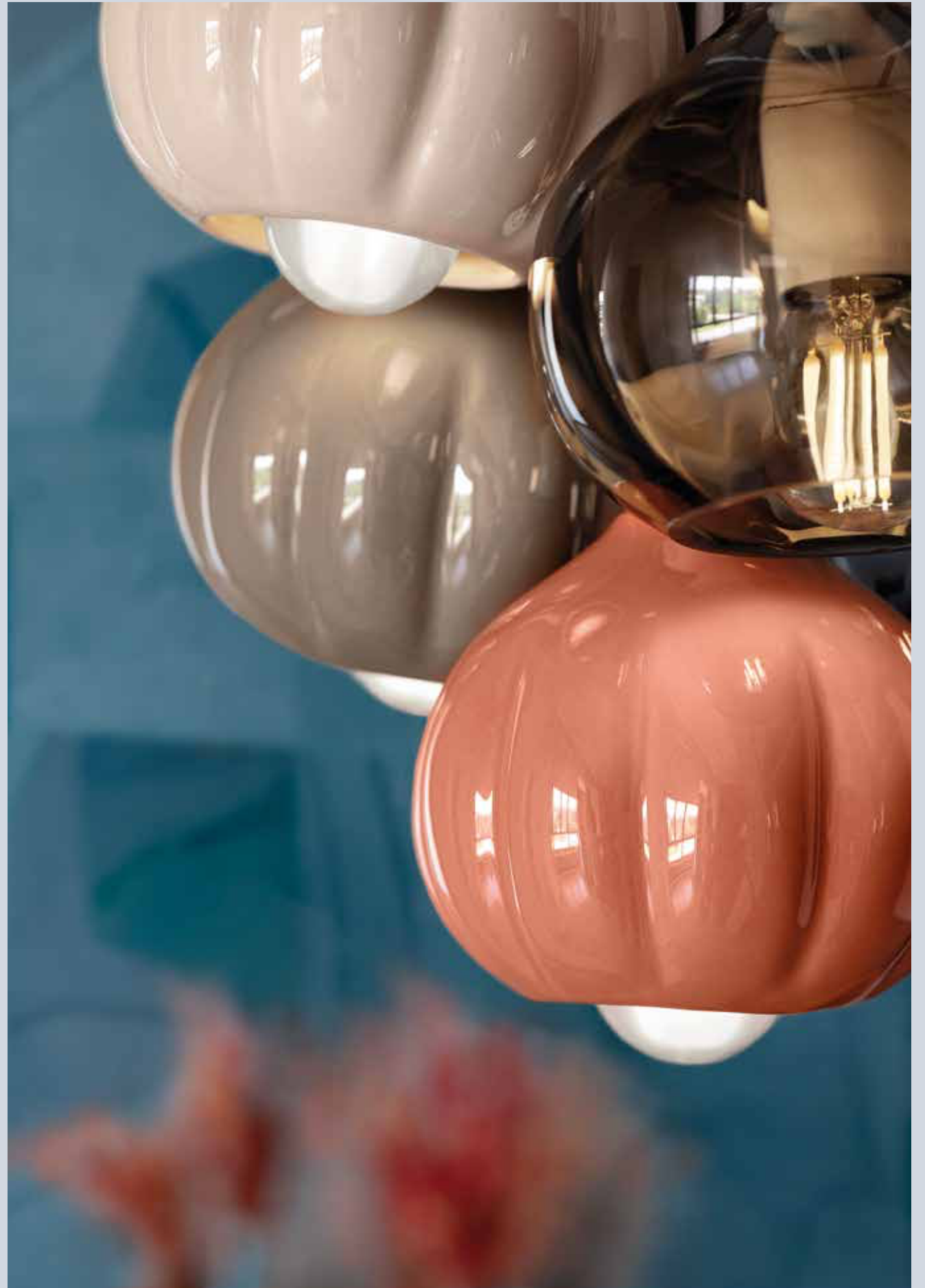

*In foto / in the picture:*  
*C2657 MIX*

F|L



*In foto / in the picture:*  
C2550 GIA, ROS

**AYRTON**

C2550 C2553

# AYRTON

C2550



Allo stesso modo delle superfici lucide e sfuggenti dei caschi da automobilismo, Ayrton riflette ed enfatizza la luce che ne impatta la superficie, disegnando sagome luminose sulla sua liscia pelle vetrosa che conferisce grande profondità allo smalto. Il suo volume viene tagliato inferiormente per massimizzare l'uscita luminosa, che riempie le superfici interne e vi fuoriesce con una resa ottimale, direzionando leggermente il fascio di luce.

*Just like the shiny and elusive surfaces of motoring helmets, Ayrton reflects and emphasizes the light that touches its surface, outlining shimmering contours that, on its smooth vitreous skin, give great depth to the varnish.*

*The lower part of its volume is cut to maximize the light output that fills its inner surfaces and optimally releases while slightly directing the light.*

In foto / in the picture:  
C2550 GIA

# AYRTON

Guardala online  
See it online



C2550



**art. C2550**  
Ceramica / ceramic



**art. C2553**  
Ceramica / ceramic



Finiture disponibili / Available finishes:

Ceramica / ceramic



GIA

ROS

AZZ

GRI



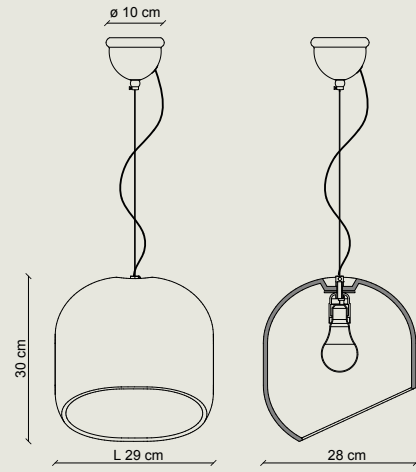

**art. C2550**

peso netto / net weight Kg 3,60

1 x MAX 53W E27

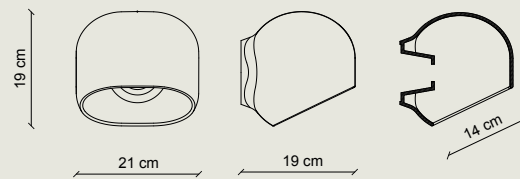

**art. C2553**

peso netto / net weight Kg 1,40

1 x MAX 40W E27



In foto / in the picture:  
C2553 ROS



In foto / in the picture:  
sx C2542 ARP  
dx C2540 VEB - C2541 GIL

**BELLOTA**

C2540 C2541 C2542

# BELLOTA

G2540



La regolarità della superficie, un'ispirazione fitomorfa espressa da un solido di rivoluzione che alterna rigidità lineare e morbidezza curvilinea, la tecnica decorativa dell'ingobbio che esalta i volumi con finiture lucide e opache sono le caratteristiche principali di una lampada a emissione diretta, la cui sorgente emerge dal volume principale senza venire schermata, per massimizzare l'emissione luminosa.

*The evenness of the surface, a phytomorphic inspiration expressed through a revolutionary solid that alternates linear rigor and wavy softness, and the decorative technique of the engobe that highlights its volumes with shiny and opaque finishes, are the main features of this direct light lamp. Its main source emerges unshielded from the main body to maximize the light emission.*

In foto / in the picture:  
C2541 GIL



# BELLOTA

Guardala online  
See it online

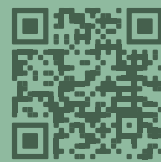

C2540



art. C2540  
Ceramica / ceramic



art. C2541  
Ceramica / ceramic



art. C2542  
Ceramica / ceramic



Finiture disponibili / Available finishes:

Ceramica / ceramic



BIG

GIL

ARP

VEB

NEC

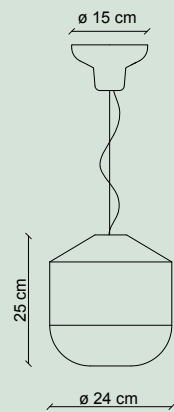

**art. C2540**

peso netto / net weight Kg 2,30  
1 x MAX 53W E27

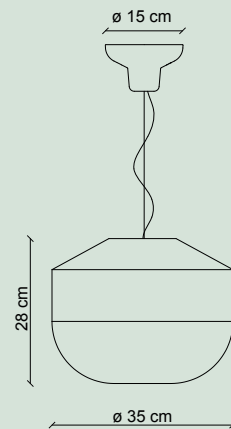

**art. C2541**

peso netto / net weight Kg 3,90  
1 x MAX 53W E27

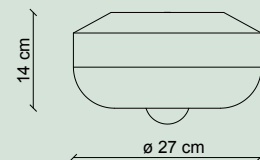

**art. C2542**

peso netto / net weight Kg 2,30  
1 x MAX 53W E27



In foto / in the picture:  
C2542 ARP



In foto / in the picture:  
C2753, C2764 MIX  
C2751 GIA

# BUMBUM

C2750	C2752	C2754	C2763
C2751	C2753	C2762	C2764

# BUMBUM



C2764

Con le sue forme sferiche e rotonde, BumBum strappa un sorriso già dal nome e resta impressa nella memoria: una lampada che trasporta chiunque la guardi in un mondo sinuoso e rassicurante, in cui non si può far altro che perdersi.

*Its name makes you smile and get stuck in your head. With its spherical and round shapes, Bumbum drives you in a sinuous and reassuring world where you can't do anything but get lost.*

In foto / in the picture:  
C2762 MIX



# BUMBUM

Guardala online  
See it online



C2751



art. C2750  
Ceramica / ceramic



art. C2751  
Ceramica / ceramic



Finiture disponibili / Available finishes:

Ceramica / ceramic



GIA APO TUR VPE



# BUMBUM

Guardala online  
See it online



C2754



art. C2752



art. C2762



art. C2753



art. C2763

Ceramica / ceramic

Ceramica / ceramic



art. C2754



art. C2764

Ceramica / ceramic



Mix disponibili / Available mixes:

Ceramica / ceramic

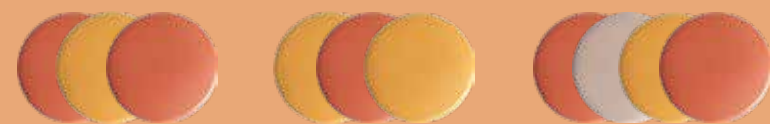

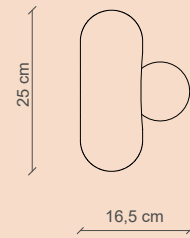

**art. C2750**

peso netto / net weight Kg 1,70

1 x MAX 25W G9

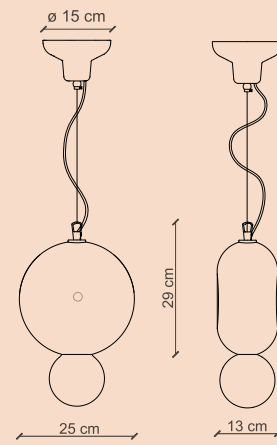

**art. C2751**

peso netto / net weight Kg 2,30

1 x MAX 53W E27



In foto / in the picture:  
C2750 APO

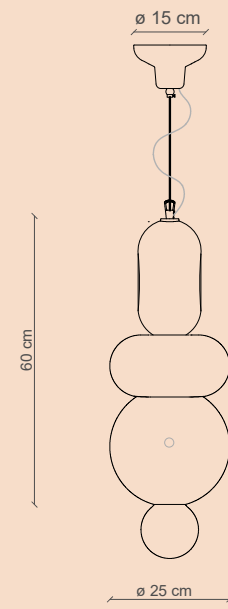

**art. C2752**    **art. C2762**  
*peso netto / net weight Kg 6,50*  
*1 x MAX 53W E27*

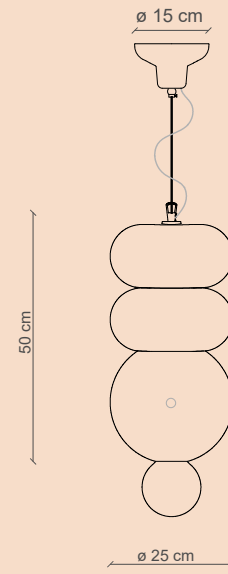

**art. C2753**    **art. C2763**  
*peso netto / net weight 6,50*  
*1 x MAX 53W E27*

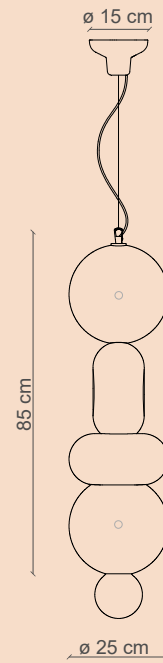

**art. C2754**    **art. C2764**  
*peso netto / net weight Kg 8,00*  
*1 x MAX 53W E27*



*In foto / in the picture:*  
*C2764 MIX*



# PAZ E AMOR

CAXIXI

In foto / in the picture:  
C2400 GIL, ROC

C2400

# CAXIXI

C2400



Ritmo e rigore. Sono i requisiti che ogni musicista brasiliano deve possedere per produrre i tipici ritmi carioca, ma sono anche le caratteristiche principali dei volumi di questa lampada a sospensione, netti e armonici, i quali rendono ancora più evidente la finitura superficiale: un parziale bagno di cristallina, realizzato a mano dal ceramista e quindi in modo sempre diverso, che una volta cotta rivela la lucentezza del prodotto in maniera selettiva, intensificando il colore e ponendo l'accento sulle forme curvilinee del volume principale.

*Tempo and precision are elements that a Brazilian musician needs to create typical carioca rhythms, but they are also the main characteristics of the main body of this suspension lamp. Clean and harmonious features highlight the finishes on its surface: a partial crystalline bath, hand-made by the ceramist and thus always different, that once fired reveals the glaze of the product, intensifying its color and emphasizing its rounded shapes.*

BRING COLOR TO LIFE

Ferroluce

In foto / in the picture:  
C2400 GIL

Guardala online  
See it online



**C2400**



**art. C2400**  
*Ceramica / ceramic*



*Finiture disponibili / Available finishes:*

*Ceramica / ceramic*



**BIG**

**GIL**

**ARP**

**ROC**

**VEB**

**GRC**

**NEC**

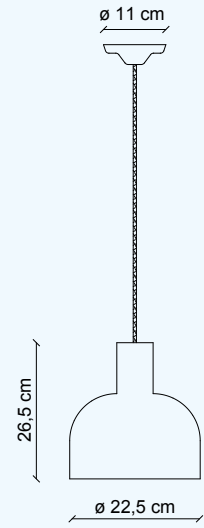

**art. C2400**

*peso netto / net weight Kg 1,17*

*1 x MAX 53W E27*



*In foto / in the picture:  
C2400 ROC*



*In foto / in the picture:*  
C2580 FAN

**CHURUATA**

C2580



# CHURRUATA



C2580

Esili e appena percettibili paralleli generati dall'andamento a falda si rincorrono, abbracciandolo, un volume teso e spigoloso che richiama le tradizionali capanne del Sud America, mentre la finitura opaca ne ammorbidisce il profilo, smorzandone i riflessi e restituendo la percezione di superfici morbide e armoniche, porose e naturali.

*Slender, barely perceptible parallels, created by the pitch pattern, chase one another embracing a taut, angular volume reminiscent of the traditional huts of South America. The matt finish softens its profile, muffling its reflections and restoring the perception of soft, harmonious, porous, natural surfaces.*

*In foto / in the picture:  
C2580 VFS*



# CHURRUATA

Guardala online  
See it online



C2580



art. C2580

Ceramica / ceramic



Finiture disponibili / Available finishes:

Ceramica / ceramic



VFS



FAN

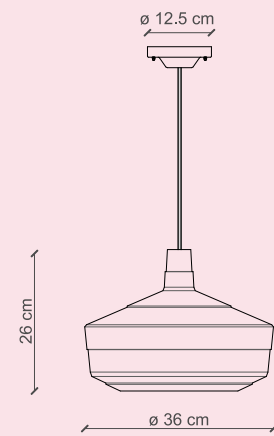

**art. C2580**

*peso netto / net weight Kg 3,37*

*1 x MAX 53W E27*

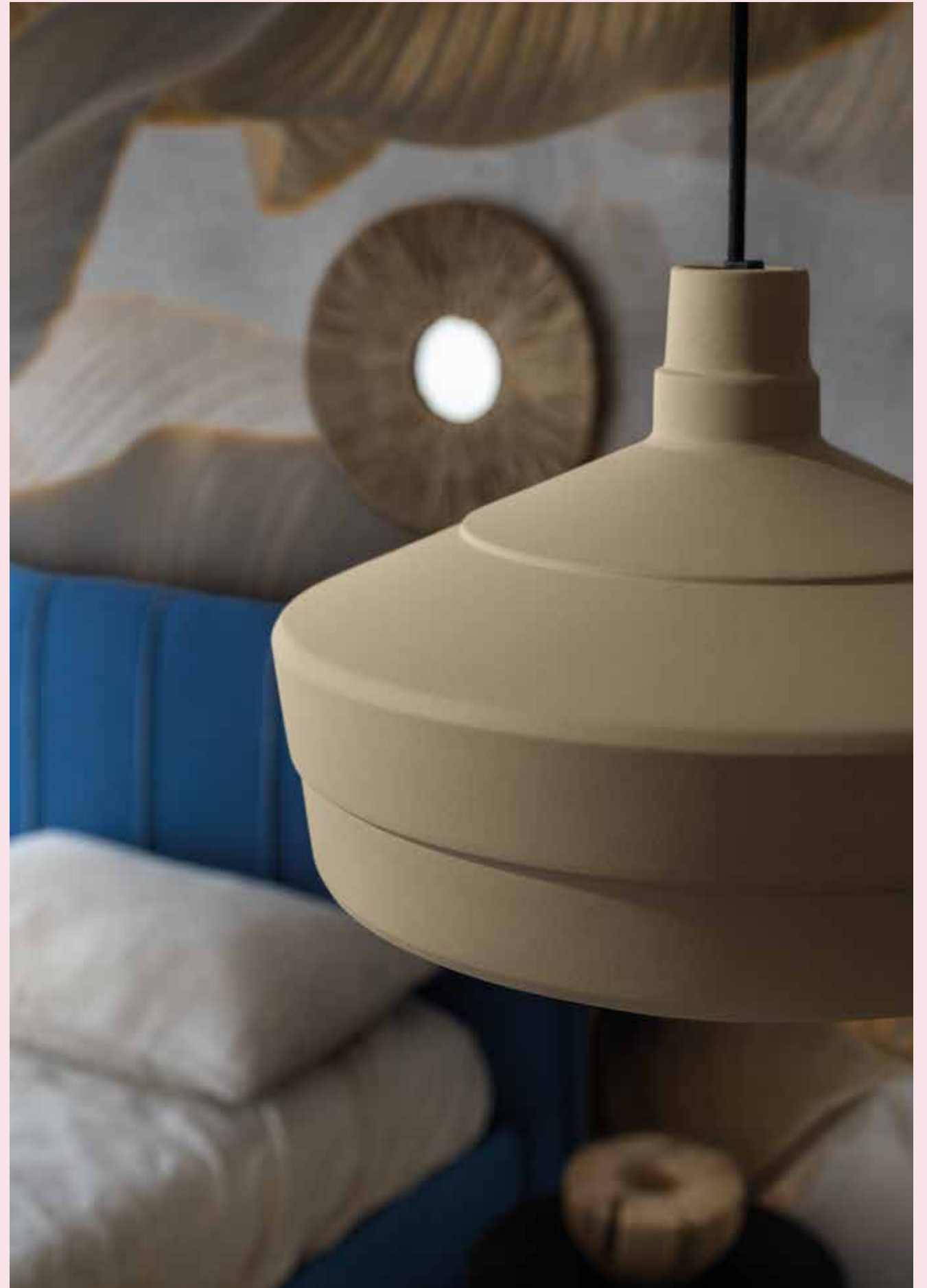

*In foto / in the picture:  
C2580 FAN*



# COPACABANA

*In foto / in the picture:*  
C2681 VSA, GIA, CRM

C2680 C2682 C2684  
C2681 C2683 C2685

# COPACABANA

C2683



Se passerete per le strade di Copacabana vi imparerete sicuramente sulla camminata di ciottoli a mosaico di Roberto Marx, una piastrellatura modernista dove architettura e natura si incontrano attraverso un nuovo linguaggio stilistico. Sovrapponendo le nostre lampade la potrete rivedere... con un tocco di luce in più.

*If you walk along the streets of Copacabana you'll for sure come across the mosaic path by Roberto Marx. It's a modernist tiled surface where architecture meets nature through a new stylistic language. Put together our lamps and you will see it... with an extra touch of light.*



In foto / in the picture:  
sx C2680 GIA  
dx C2682 GIA

BRING COLOR TO LIFE

Ferroluce

# COPACABANA

Guardala online  
See it online



C2682



Finiture disponibili / Available finishes:

Ceramica / ceramic



CRM GRS GIA VSA MOK

Mix disponibili / Available mixes:

Ceramica / ceramic



art. C2680  
Ceramica / ceramic



art. C2683  
Ceramica / ceramic



art. C2681  
Ceramica / ceramic



art. C2684  
Ceramica / ceramic



art. C2682  
Ceramica / ceramic



art. C2685  
Ceramica / ceramic



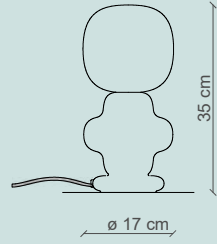

**art. C2680**  
peso netto / net weight Kg 2,12  
1 x MAX 28W E14

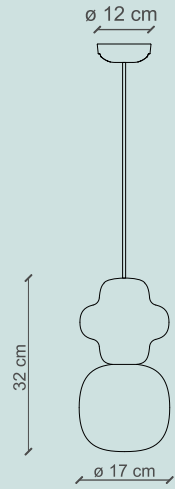

**art. C2681**  
peso netto / net weight 2,12  
1 x MAX 28W E14

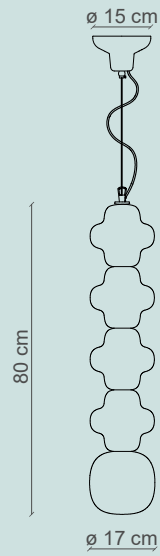

**art. C2682 - C2685**  
peso netto / net weight Kg 5,00  
1 x MAX 28W E14



In foto / in the picture:  
C2680 GIA



# CORCOVADO

*In foto / in the picture:*  
C2740 GIV  
C2742 VLT  
C2744 AZG

C2740 C2742 C2744



# CORCOVADO

C2740



**Eccentrica e colorata, la lampada prende il nome da uno dei monti più famosi di Rio de Janeiro, sulla cui cima è posizionato il Cristo Redentore.**

**I colori accesi di Corcovado ricordano quelli della bandiera brasiliana, e portano nell'ambiente la vivacità e la vitalità tipiche del carnevale di Rio.**

*Extravagant and colorful. This lamp takes its name from one of the most famous mountains in Rio de Janeiro, on the top of which stands the statue of Christ the Redeemer. The bright colors of Corcovado recall those of the Brazilian national flag and give the room the typical vitality of the Carnival in Rio.*



# CORCOVADO

Guardala online  
See it online



C2744



art. C2740  
Ceramica / ceramic  
Vetro / glass



art. C2742  
Ceramica / ceramic  
Vetro / glass



art. C2744  
Ceramica / ceramic



Finiture disponibili / Available finishes:

Ceramica / ceramic



AZG

AZP

APM

Vetro / glass



GLT

VLT

AZG

GIV

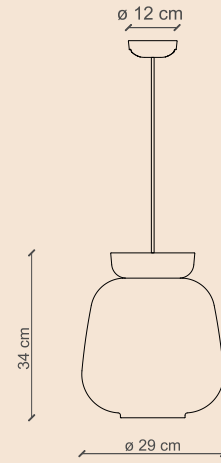

**art. C2740**

peso netto / net weight Kg 2,72  
1 x MAX 53W E27

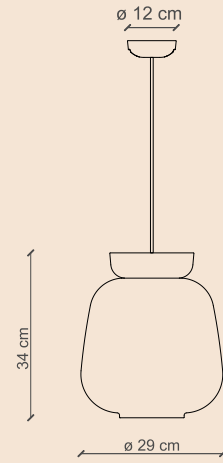

**art. C2742**

peso netto / net weight Kg 2,72  
1 x MAX 53W E27

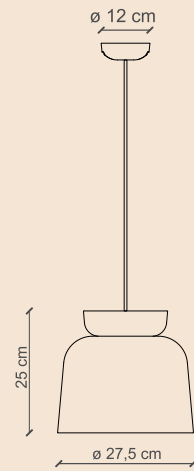

**art. C2744**

peso netto / net weight Kg 2,77  
1 x MAX 53W E27



In foto / in the picture:  
C2740 AZG  
C2742 VLT



In foto / in the picture:  
C2710

**LARIAT**

C2710 C2711 C2712

# LARIAT

C2711



Come in un gioiello, i brillanti elementi ceramici di Lariat si susseguono verticali a formare una variegata catena multicolore, che procede alternando le geometrie sino ad arrivare all'elemento più prezioso che si trova alla sua estremità e che contiene l'elemento luminoso.

*Just like a jewel, the bright ceramic elements are organized in a vertical series that forms a varied and colorful chain. This chain progresses while alternating geometries until it reaches the most important element that contains the lighting element.*



Guardala online  
See it online



C2711



art. C2710  
*Vetro / glass*



art. C2711  
*Vetro / glass*



art. C2712  
*Vetro / glass*



Finiture disponibili / Available finishes:

Vetro / glass



BLT

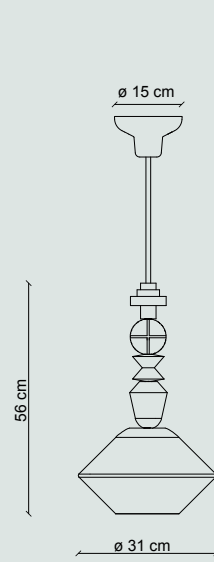

**art. C2710**  
peso netto / net weight Kg 3,00  
1 x MAX 53W E27

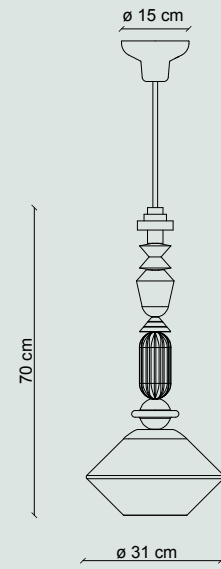

**art. C2711**  
peso netto / net weight Kg 3,57  
1 x MAX 53W E27

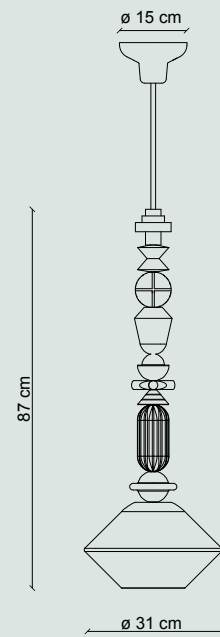

**art. C2712**  
peso netto / net weight Kg 3,87  
1 x MAX 53W E27



In foto / in the picture:  
C2712



In foto / in the picture:  
C2530 VPE  
C2511 GIA

C2510 C2512 C2531  
C2511 C2530 C2532



Guardala online  
See it online



C2511



art. C2510  
Ceramica / ceramic



art. C2511  
Ceramica / ceramic



art. C2512  
Ceramica / ceramic



art. C2530  
Ceramica / ceramic



art. C2531  
Ceramica / ceramic



art. C2532  
Ceramica / ceramic



Finiture disponibili / Available finishes:

Ceramica / ceramic



GIA

VPE

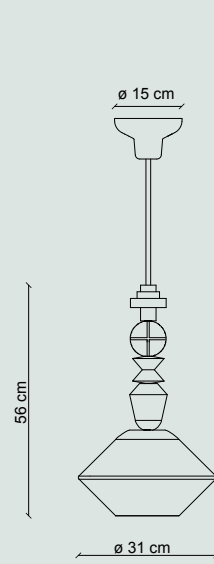

**art. C2510**  
peso netto / net weight Kg 2,95  
1 x MAX 53W E27

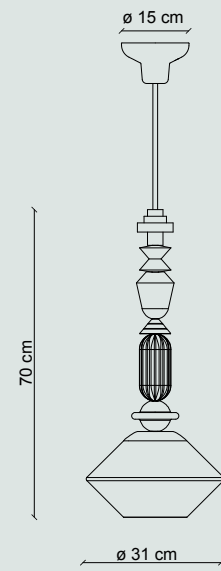

**art. C2511**  
peso netto / net weight Kg 3,45  
1 x MAX 53W E27

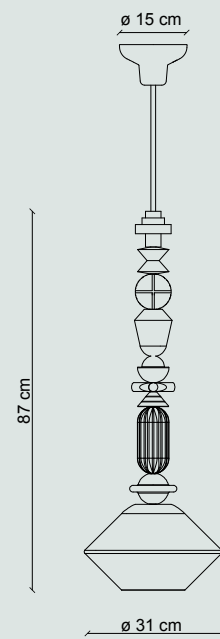

**art. C2512**  
peso netto / net weight Kg 4,00  
1 x MAX 53W E27

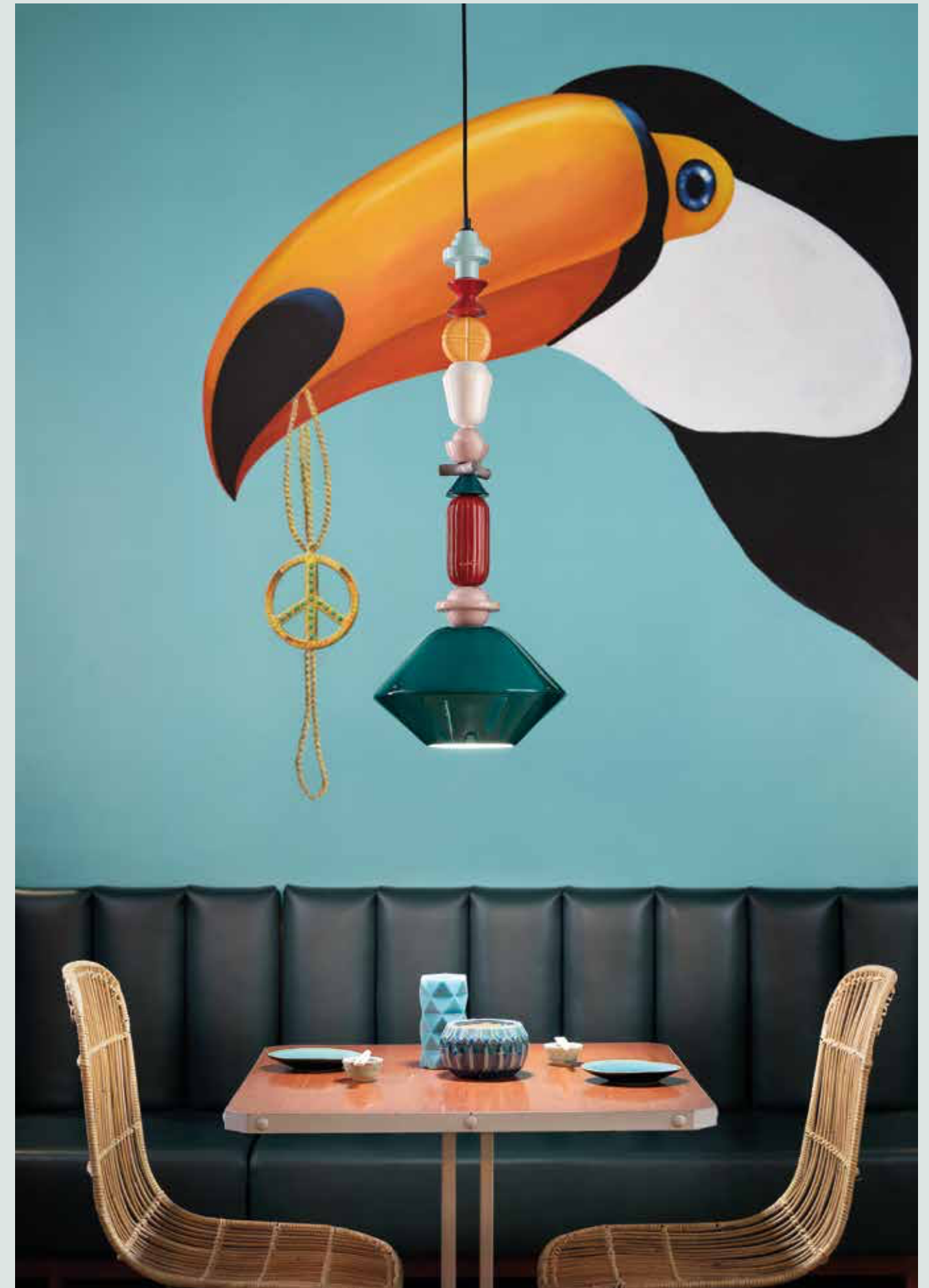

In foto / in the picture:  
C2512 VPE

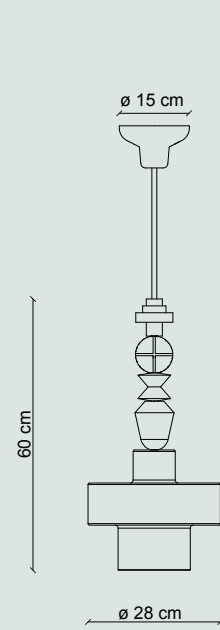

**art. C2530**

peso netto / net weight Kg 3,15  
1 x MAX 53W E27

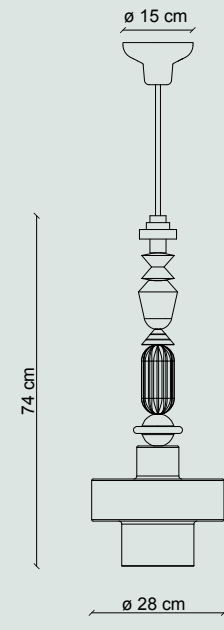

**art. C2531**

peso netto / net weight Kg 3,65  
1 x MAX 53W E27

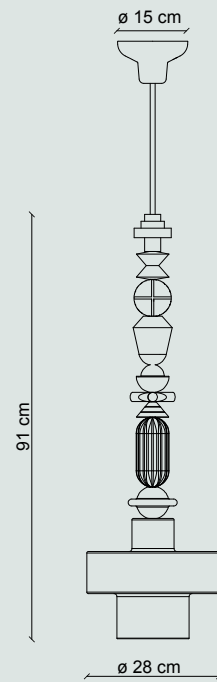

**art. C2532**

peso netto / net weight Kg 4,40  
1 x MAX 53W E27



In foto / in the picture:  
C2510 VPE



# MADAME GRÈS

*In foto / in the picture:*  
C2570 RSC, GRT  
C2571 GRN

C2570 C2571 C2572 C2573

# MADAME GRÈS



C2570

Con le sue superfici mosse e gli intagli verticali che si ripetono lungo tutto il suo perimetro, il diffusore di Madame Grès ci ricorda più un capo d'abbigliamento plissettato o una confezione tessile morbida e mossa piuttosto che un elemento rigido e statico. Le sue superfici, decorate da una finitura a ingobbio opaco che ne ingentilisce ancor più le forme rendendole tenui e setose, si aprono attorno alla sorgente luminosa, generando un ampio fascio di luce che illumina in modo consistente gli ambienti circostanti.

*With its undulated surfaces and vertical inlays that repeat themselves along the whole perimeter, the Madame Grès diffuser reminds us of a pleated garment or a fabric rather than a rigid and motionless element. Its surfaces are decorated with opaque engobed finishes that all the more refine its outlines, making them soft and silky. They open up around the light source, creating a wide beam that illuminates the surrounding environment.*

*In foto / in the picture:  
C2570 RSC*

# MADAME GRÈS

Guardala online  
See it online

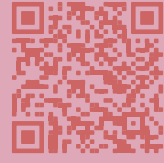

C2571



art. C2570  
*Ceramica / ceramic*



art. C2571  
*Ceramica / ceramic*



art. C2572  
*Ceramica / ceramic*



art. C2573  
*Ceramica / ceramic*



Finiture disponibili / Available finishes:

Ceramica / ceramic



BIN RSC GRT GRN

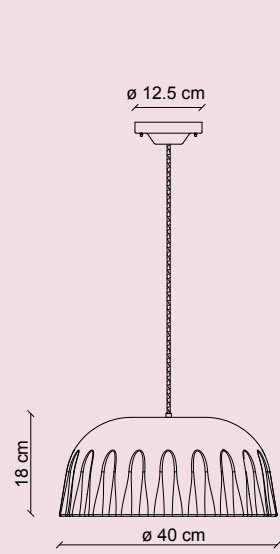

**art. C2570**

peso netto / net weight Kg 3,10  
1 x MAX 53W E27

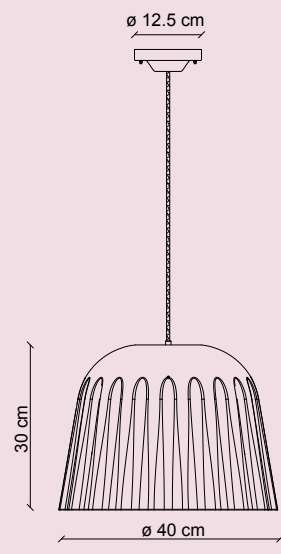

**art. C2571**

peso netto / net weight Kg 4,60  
1 x MAX 53W E27

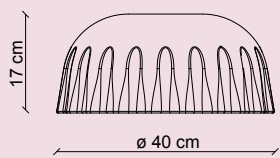

**art. C2572**

peso netto / net weight Kg 3,40  
1 x MAX 53W E27

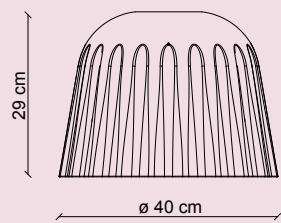

**art. C2573**

peso netto / net weight Kg 4,90  
1 x MAX 53W E27



In foto / in the picture:  
C2572 GRT



# MARACANÀ

In foto / in the picture:  
C2745 IAZ  
C2741 SAG

C2741 C2743 C2745



# MARACANÀ

C2741



Lampada costituita da due parti: quella superiore, in ceramica e dalla forma a ciotola, e quella inferiore, in vetro verniciato e naturale, che richiama, con il suo aspetto circolare leggermente rialzato, la costruzione degli stadi e delle arene. Da qui il nome della lampada, riferito allo stadio brasiliano per eccellenza: Maracanà.

*This lamp is composed of two parts: the bowl-shaped upper part is made of ceramic and the lower part is made of painted and natural glass. Its round shape recalls the structure of stadiums and arenas. Its name refers to the Brazilian stadium par excellence: Maracanà.*



Guardala online  
See it online



C2745



**art. C2741**  
Ceramica / ceramic  
Vetro / glass



**art. C2743**  
Ceramica / ceramic  
Vetro / glass



**art. C2745**  
Ceramica / ceramic



Finiture disponibili / Available finishes:

Ceramica / ceramic



IAZ

GIV

APA

Vetro / glass



ALT

MLT

SAG

MOA

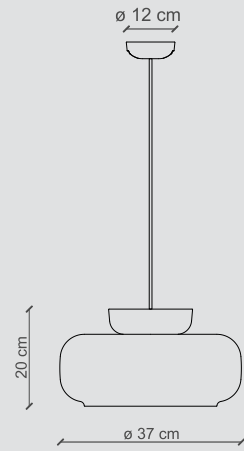

**art. C2741**

peso netto / net weight Kg 2,90  
1 x MAX 53W E27

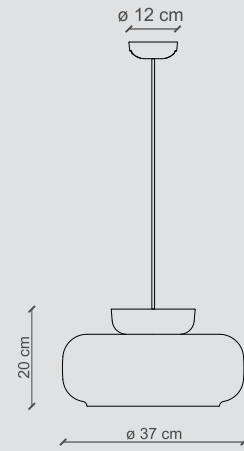

**art. C2743**

peso netto / net weight Kg 2,90  
1 x MAX 53W E27

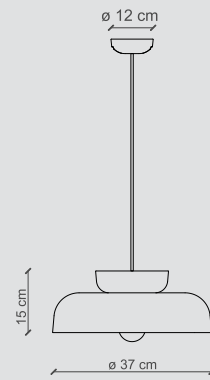

**art. C2745**

peso netto / net weight Kg 2,68  
1 x MAX 53W E27



In foto / in the picture:  
C2741 SAG



In foto / in the picture:  
C2502 MIB

PI

C985 C1792 C2500 C2502  
C986 C1793 C2501

C2500



La precisione formale e la rigidità dei volumi è il carattere distintivo di questa collezione che, coniugando sapientemente forme geometriche regolari a pattern caratteristici ed elementi tecnici a scomparsa compone figure di grande impatto e quasi metafisiche, capaci di inserirsi senza alcun problema in ambienti di differente ispirazione e carattere. Disponibile in molte varianti e applicazioni, la collezione Pi fa un ineccepibile utilizzo delle tecniche di decorazione ceramica, che riquadrano superfici ricche, piacevoli e bilanciate.

*The formal precision and rigor of the volumes are the distinctive features of this collection that, skillfully combining regular geometric shapes, distinctive patterns and concealed technical elements, create shapes of great impact that are almost metaphysical and are able to fit perfectly in different environments. Available in several variants and applications, the Pi collection makes impeccable use of decorative ceramic techniques as they surround rich, pleasant and balanced surfaces.*

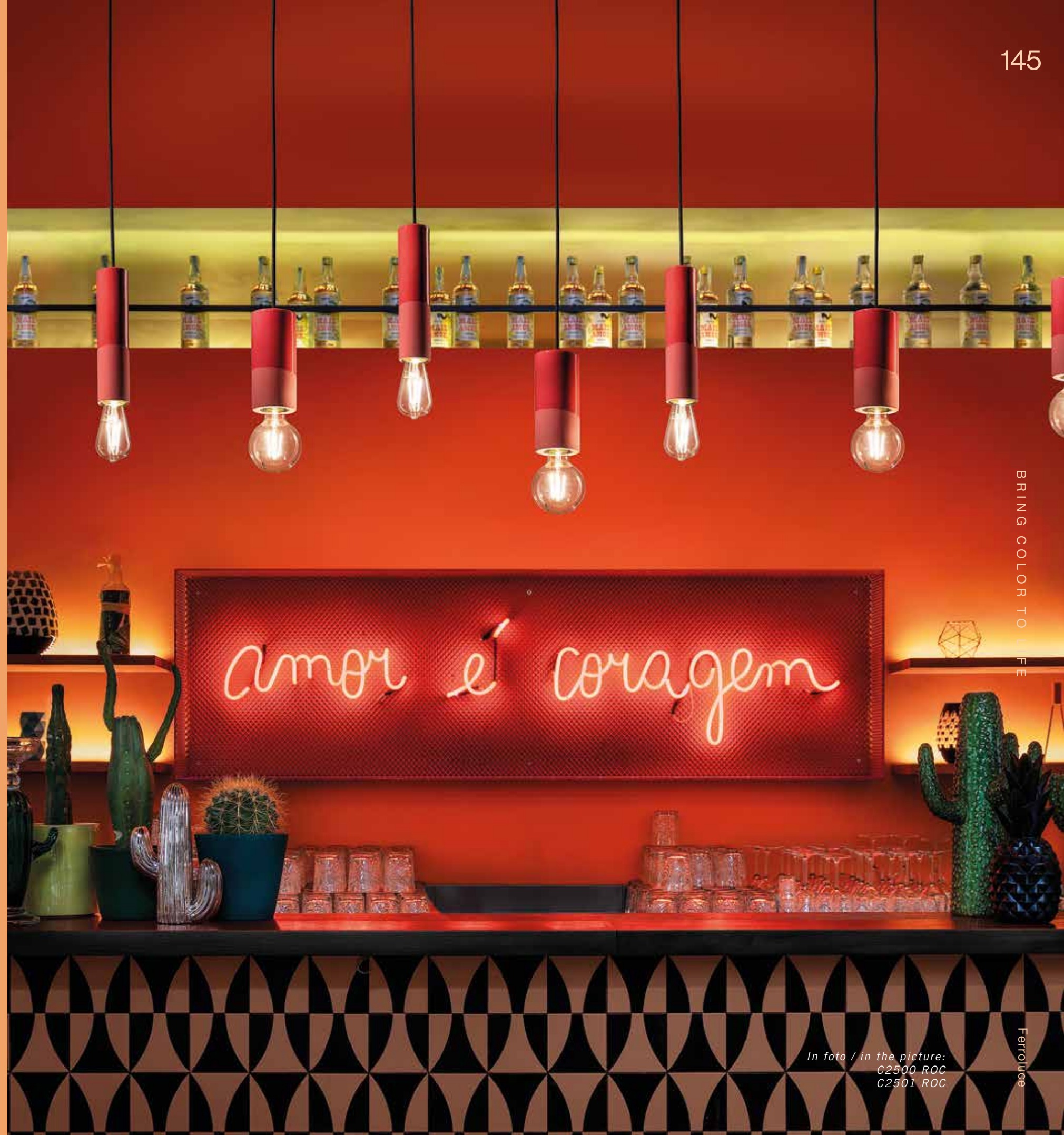



**C2502**



**art. C1792**  
*Ceramica / ceramic*

**art. C1793**  
*Ceramica / ceramic*



**art. C2502**  
*Ceramica / ceramic*



Finiture disponibili / Available finishes:

Ceramica / ceramic



**BIG GIL ARP ROC VEB NEC MIR MIB**



art. C985  
Ceramica / ceramic



art. C986  
Ceramica / ceramic



art. C2500  
Ceramica / ceramic



art. C2501  
Ceramica / ceramic



Finiture disponibili / Available finishes:

Ceramica / ceramic



BIG

GIL

ARP

ROC

VEB

NEC

MIR

MIB

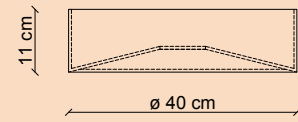

**art. C1792**

*peso netto / net weight Kg 2,95*  
*1 x MAX 77W E27*

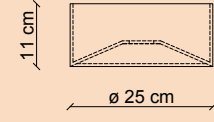

**art. C1793**

*peso netto / net weight Kg 1,00*  
*1 x MAX 77W E27*

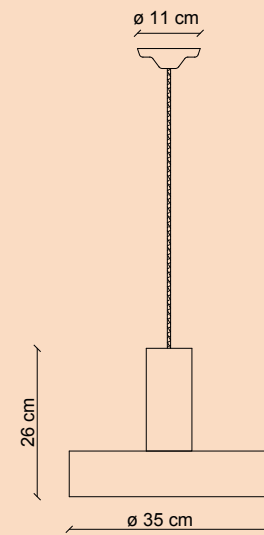

**art. C2502**

*peso netto / net weight Kg 3,40*  
*1 x MAX 77W E27*



*In foto / in the picture:*

*C2502 MIB*



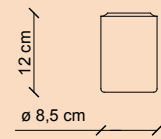

**art. C985**

peso netto / net weight Kg 0,39  
1 x MAX 28W E14

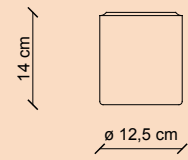

**art. C986**

peso netto / net weight Kg 0,90  
1 x MAX 53W E27

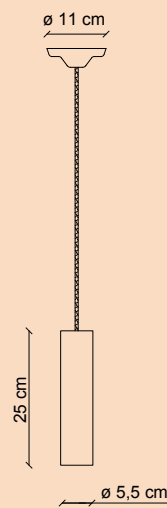

**art. C2500**

peso netto / net weight Kg 0,80  
1 x MAX 77W E27

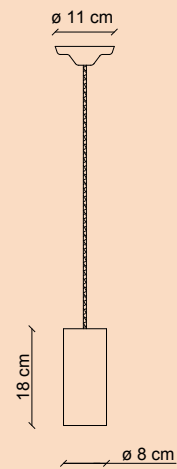

**art. C2501**

peso netto / net weight Kg 0,88  
1 x MAX 77W E27

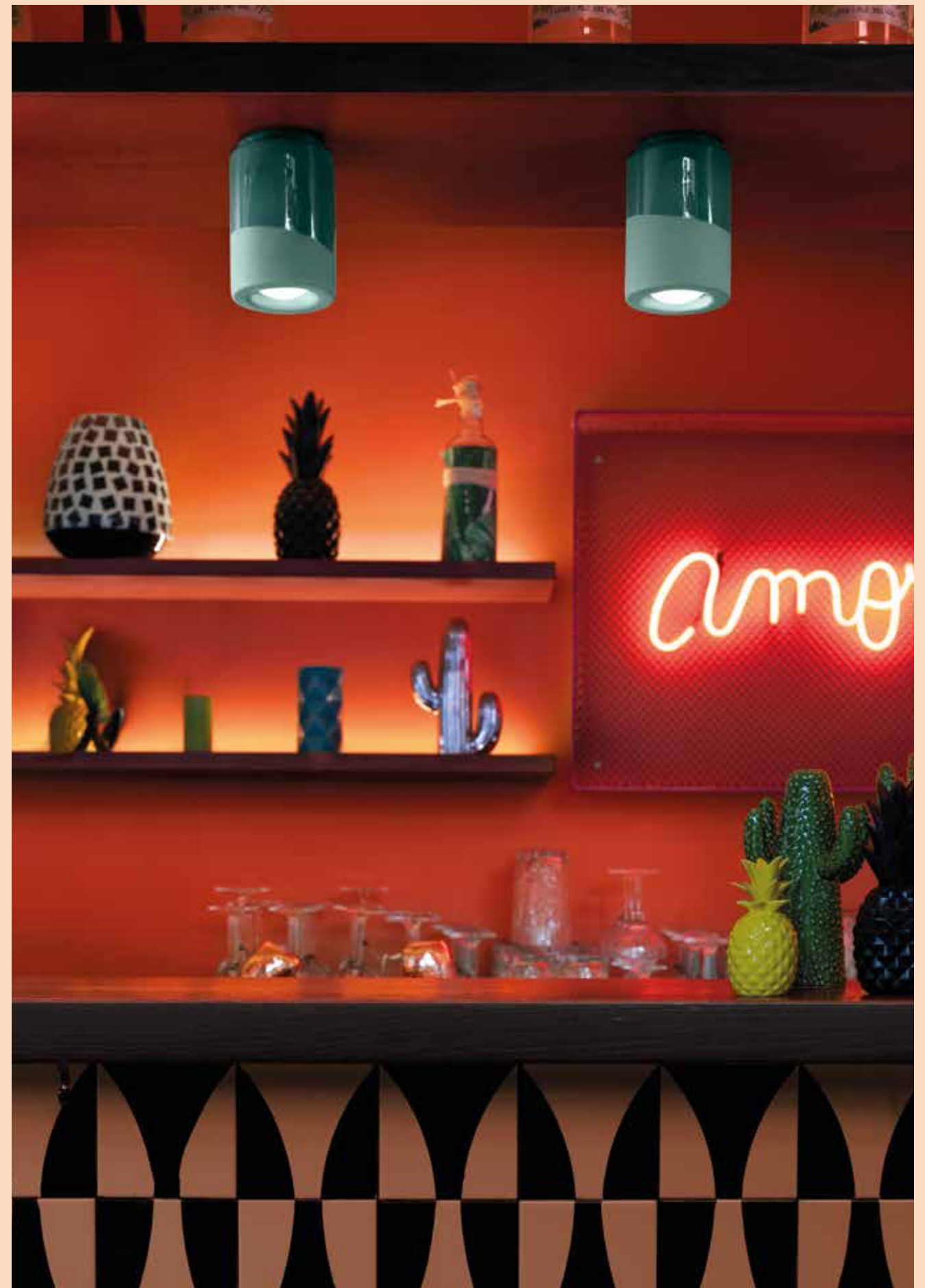

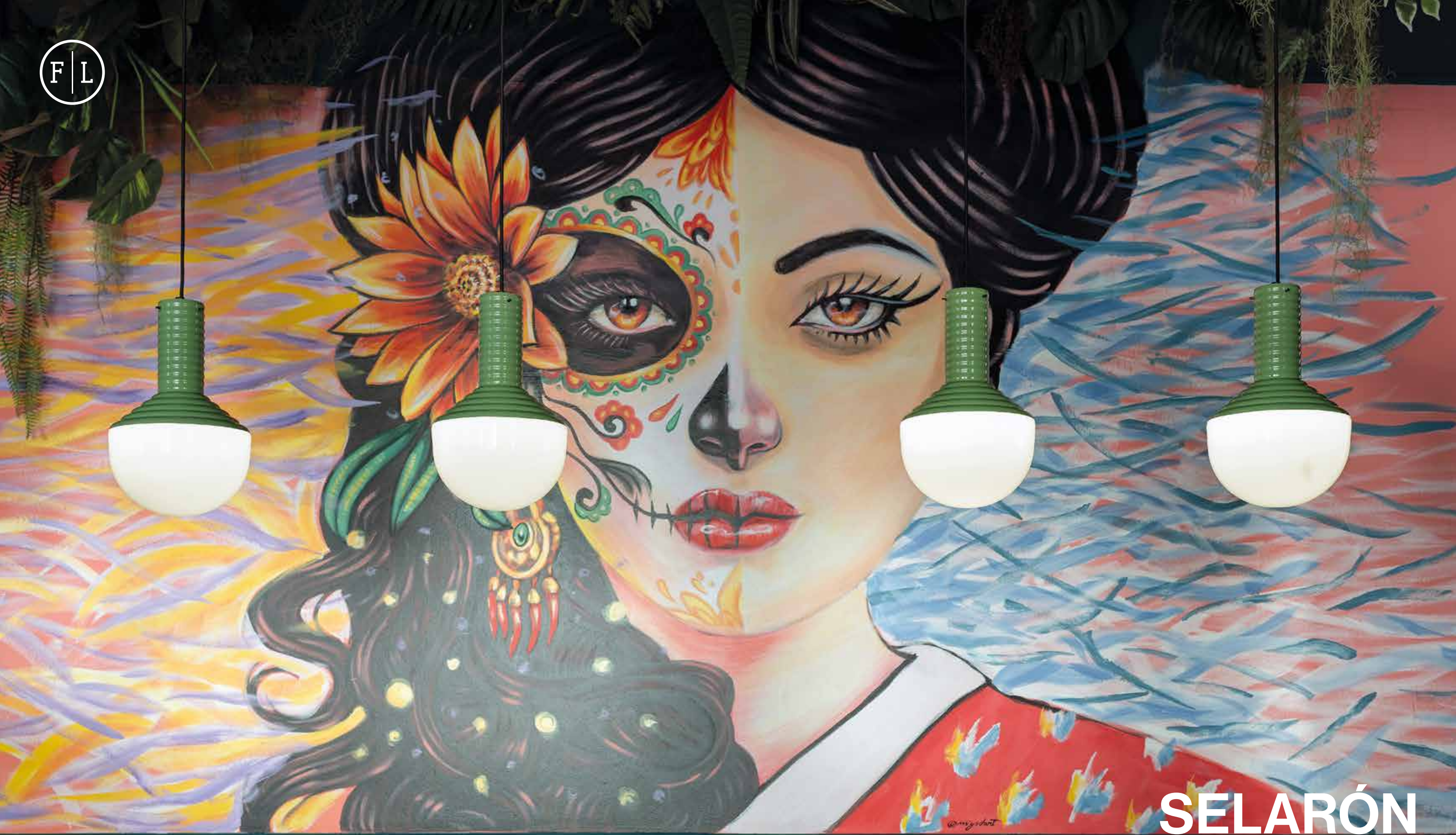

**SELARÓN**

# SELARÓN



C2730

La forma scalettata della lampada prende a modello l'escadaria più famosa del Brasile, decorata dall'artista Jorge Selarón, e raffigura la continua evoluzione stilistica di Ferroluce, unendo la passione per l'innovazione con la continua sperimentazione di forme e colori.

*The stair-shape of the lamp takes inspiration from the most famous escadaria in Brazil, a work by the artist Jorge Selarón. It represents the continuous stylistic evolution of Ferroluce that combine the passion for innovation with the constant experimentation of shapes and colors.*



# SELARÓN

Guardala online  
See it online

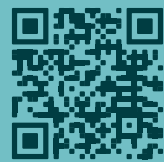

C2730



art. C2730  
*Vetro / glass*



Finiture disponibili / Available finishes:

Vetro / glass



GIA

APO

BLB

VSA

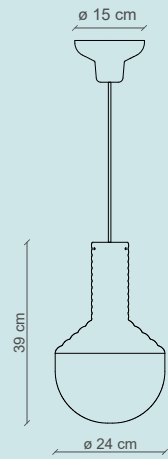

**art. C2730**

*peso netto / net weight Kg 2,80*

*1 x MAX 53W E27*



*In foto / in the picture:  
C2730 VSA*

# STORIA dell'Azienda

COMPANY HISTORY

**I TEMPI CAMBIANO, FERROLUCE SI EVOLVE.**

*TIMES CHANGE, FERROLUCE EVOLVES*

Ferroluce nasce nel 1982 dalla volontà di Miriam e Valter Valentinuz di creare delle lampade frutto dell'amore per la lavorazione della materia, prima del ferro e poi della ceramica.

Oggi l'azienda, grazie al supporto dei figli Monica e Giulio, guarda alla tradizione mantenendo un forte legame con la lavorazione artigianale e la materia, ma apportando al contempo nuove soluzioni tecniche e formali per uscire dagli schemi predefiniti ed esplorare nuovi mercati.

L'obiettivo? Dare vita a lampade capaci di far innamorare tutto il mondo, dalla Finlandia all'Asia fino agli Stati Uniti, e che sorprendono chiunque le guardi.

*Ferroluce was born in 1982. Miriam and Valter Valentinuz wanted to create lamps, which would inspire the fruit of their love for iron and ceramic manufacturing.*

*Today the company, run with the help of Monica and Giulio, their daughter and son, still maintains a strong bond with the tradition through handmade manufacturing and materials, but at the same time it finds new technical and formal solutions to go beyond set patterns and explore new markets.*

*The aim is to create lamps for the whole world fall in love with, amazing everyone from Finland to Asia to the United States.*

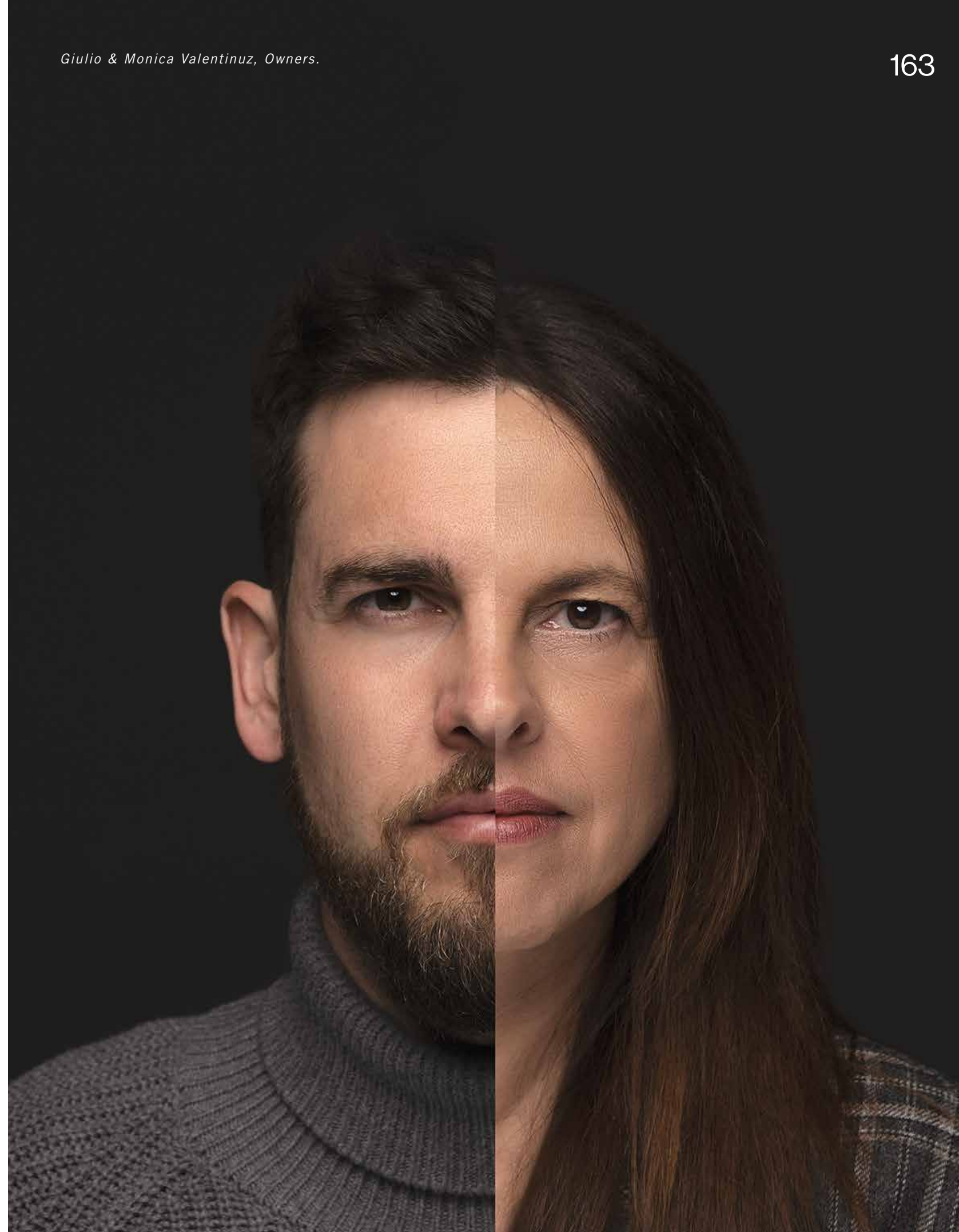

# SVILUPPO

# del Brand

BRAND EVOLUTION



Dal ferro alla ceramica  
per arrivare all'esplosione  
di colori.

*From iron to ceramic with  
an explosion of color*

**DAL FERRO ALLA CERAMICA AL COLORE.**  
*FROM IRON TO CERAMIC AND COLOR*

L'azienda Ferroluce inizia il suo viaggio nella produzione di lampade creando plafoniere in ferro battuto: un materiale molto versatile e all'epoca apprezzato per la sua modernità ed eleganza. Col passare degli anni è cresciuta in noi l'esigenza di ricercare materiali diversi, che non solo avessero delle caratteristiche tecniche ottimali, ma che fossero legati anche ai nostri valori aziendali. Tutto questo lo abbiamo trovato nella ceramica: organica, duttile e particolarmente adatta alla lavorazione manuale, ancora oggi guida il nostro lavoro e, insieme allo studio di colori e stili innovativi, ci permette di sperimentare di anno in anno soluzioni d'illuminazione sempre nuove, che si adattano ai tempi che cambiano.

*Ferroluce began its history in lamp production, creating wrought iron ceiling lamps. Wrought iron is a very versatile material and at that time it was highly regarded for its elegance and modernity.*

*During the years we had the need to find new materials with excellent technical features but also in line with our company values.*

*We found all this in ceramic: it's organic, ductile and particularly suitable for manual processing.*

*Even now it still guides our work, and, together with the study of innovative colors and styles, it allows us to continuously explore new lighting solutions adaptive to changing times.*

**LAMPADE "SLOW", PERCHÉ NATE DALLA PAZIENZA E DALL'ATTENZIONE.***"SLOW" LAMPS, RESULT OF PATIENCE AND CARE*

Vengono alla luce con pazienza, secondo un processo produttivo attento e lento che esalta la lavorazione di ogni dettaglio: sono le nostre lampade, realizzate una ad una attraverso quel che in gergo si definisce Slow Manufacturing, un metodo che valorizza la creatività e l'abilità manuale dei nostri artigiani permettendoci di creare prodotti di grande pregio, interamente fatti a mano, perfetti nelle loro imperfezioni.

*Our lamps are made with patience due to a slow and precise manufacturing process that gives attention to every detail. They are handmade one by one through our "Slow Manufacturing" process. This approach enhances the creativity and manual skills of our craftsmen and allowing us to create completely handmade products of great value, that are perfect in their imperfections.*



# slow MANUFACTURING

# ORGANIC

Abbiamo scelto la via della sostenibilità ben prima che questa fosse un tema di spicco all'interno della società. Adottando per le nostre lampade la ceramica come unico materiale produttivo, composta esclusivamente da argilla, quarzo e allumina, ci siamo voluti simbolicamente connettere alla natura che ci circonda. Per illuminare le vostre case con prodotti che racchiudono, in ogni loro dettaglio, la naturalità e la bellezza più pura. Come natura comanda.

*We chose the philosophy of sustainability long before it was a prominent issue within society. We create a symbolic connection with nature by choosing ceramic as the only material. It's exclusively made of clay, quartz and alumina.*

*Our products ensure in each and every detail the purest naturalness and beauty, just as nature intended.*



**UN LEGAME PRIMORDIALE CON LA NATURA.**  
*A PRIMITIVE BOND WITH NATURE*



# CERAMICA

CERAMIC

**LA LAVORAZIONE ARTIGIANALE PER DONARE UNICITÀ A OGNI LAMPADA.**  
UNIQUE HANDMADE LAMPS



Ogni prodotto Ferroluce è fatto a mano in un contesto che esula dalla produzione in massa. Grazie all'uso della ceramica, materiale rappresentativo dello spirito del brand, estremamente versatile e facilmente lavorabile, le nostre soluzioni di illuminazione rispettano l'ambiente e la tradizione di famiglia, donando al cliente un'eccellenza e un'unicità inimitabili.

*Every Ferroluce product is handmade - far from the idea of mass production. Thanks to the characteristics of the ceramic, an extremely versatile and malleable material, our lighting solutions respect the environment and our family tradition, giving customers an unmatched excellence and uniqueness.*



# IL COLORE

COLOR

**UN TUFFO NELLE SFUMATURE FERROLUCE.**  
A DIP IN FERROLUCE NUANCES

Amiamo sperimentare con i colori, e lo facciamo seguendo sempre un obiettivo: la ricerca della bellezza. Siamo convinti infatti che ogni singola sfumatura sia indispensabile per donare alle nostre lampade un carattere originale e distintivo, comunicando al tempo stesso emozioni e sentimenti diversi per ognuno di noi. Soprattutto nella nostra collezione DECò, abbiamo voluto dare risalto alle caratteristiche di ogni prodotto abbinando tra loro differenti tonalità di colore. Per creare lampade capaci di regalare emozioni impossibili da esprimere soltanto in forme

*We love to experiment with colors and our aim is only one: the pursuit of beauty.*

*We believe that every single nuance is essential to give our lamps an original and distinctive character that conveys different emotions and feelings to each of us.*

*Especially in our Decò collection, we wanted to emphasize the characteristics of every product matching different nuances to create lamps that are able to emit emotions, not only through their shape but also through color.*

TUTTI I NOSTRI ARTICOLI SONO PRODOTTI ESCLUSIVAMENTE IN ITALIA  
E RISPETTANO RIGOROSAMENTE LE NORMATIVE **CE**.

*ALL OUR PRODUCTS ARE MADE IN ITALY AND BUILT  
IN THE RESPECT OF **CE** LAWS.*

L'AZIENDA SI RISERVA IL DIRITTO DI MODIFICARE SENZA PREAVVISO  
TUTTE LE FINITURE E GLI ARTICOLI PRESENTI IN QUESTO CATALOGO.  
I COLORI REALI DELLE FINITURE POSSONO DIFFERIRE DA QUELLE STAMPATE.

*THE COMPANY RESERVES THE RIGHT TO MODIFY WITHOUT WARNING  
ALL THE FINISHES AND PRODUCTS INCLUDED WITHIN THIS CATALOGUE.  
THE ACTUAL COLORS OF THE FINISHES MAY BE DIFFERENT THAN PRINTED ONES.*

associato



consorzio per la raccolta e lo smaltimento  
delle apparecchiature di illuminazione

COPYRIGHT FERROLUCE SRL®

Location: Temakinho Milano  
Printed by: Poligrafiche San Marco - ITALY  
Graphic: **RGB**

# FERROLUCE

*Scansionando i QR code all'interno del catalogo è possibile collegarsi al sito  
www.ferroluce.it dove potrai trovare immagini, finiture, schede tecniche,  
istruzioni di montaggio, disegni 2d, file 3ds e scaricare facilmente anche gli altri  
due cataloghi Ferroluce.*

*It is possible to access the website www.ferroluce.it by scanning the QR code  
in the catalogue. You can find images, finishes, technical data, installation  
instructions, 2D models, 3D files and download all Ferroluce catalogues.*



## STABILIMENTO PRODUCTION DEPARTMENT

Z.I. I VIA ARMENTARESSA nr.10  
34076 ROMANS D'ISONZO (GO) | ITALIA  
T. +39 0481 909541

## SEDE ED ESPOSIZIONE HEAD OFFICE AND SHOWROOM

VIA XXV MAGGIO nr.17  
34076 ROMANS D'ISONZO (GO) | ITALIA

## SEDE AMMINISTRATIVA MANAGEMENT

VIA TIRO nr.19  
30126 VENEZIA LIDO (VE) | ITALIA

INFO@FERROLUCE.IT | WWW.FERROLUCE.IT

